

Scale 1:10

PROPRIETARY AND CONFIDENTIAL
 THE INFORMATION CONTAINED IN THIS DRAWING IS THE SOLE PROPERTY OF THE UNIVERSITY OF MAINE. ANY REPRODUCTION IN PART OR AS A WHOLE WITHOUT THE WRITTEN PERMISSION OF THE UNIVERSITY OF MAINE IS PROHIBITED.

		UNLESS OTHERWISE SPECIFIED:		NAME	DATE
		DIMENSIONS ARE IN INCHES	DRAWN	Keith Jewett	11/4/14
		TOLERANCES:	CHECKED		
		FRACTIONAL ± .01	ENG APPR.		
		ANGULAR: MACH ± BEND ±	MFG APPR.		
		TWO PLACE DECIMAL ±	Q.A.		
		THREE PLACE DECIMAL ±	COMMENTS:		
		INTERPRET GEOMETRIC TOLERANCING PER:			
		MATERIAL			
		Various			
NEXT ASSY	USED ON	FINISH			
		Various			
APPLICATION		DO NOT SCALE DRAWING			

Parts to be Removed		
TITLE: Current Skid Isometric View		
SIZE A	DWG. NO. 0000-00-01	REV -
SCALE: 1:6	WEIGHT: 43 lbs	SHEET 2 OF 3

5

4

3

2

1

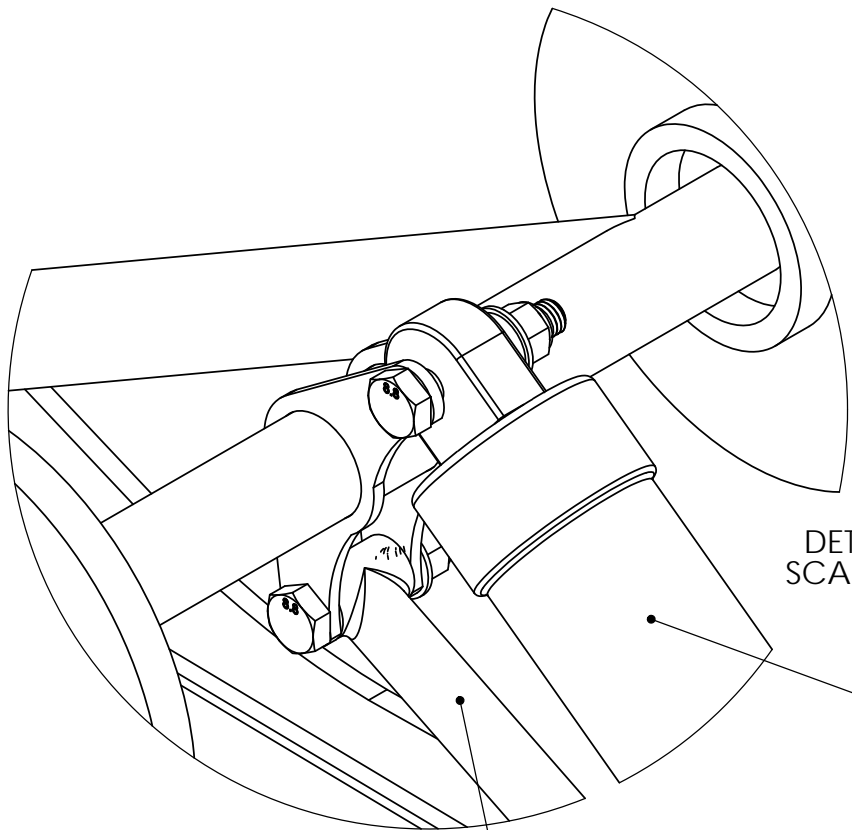

DETAIL A
SCALE 1 : 2

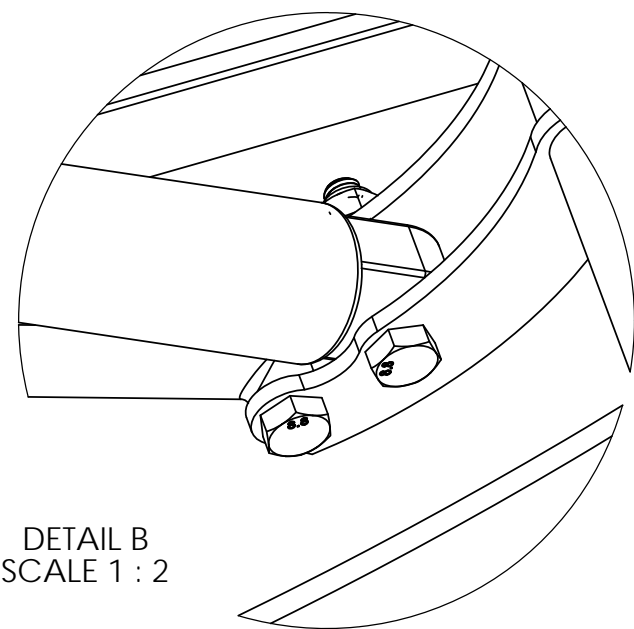

DETAIL B
SCALE 1 : 2

1

2

Part	Quantity	Mfr Num	Description	Material	Weight
1	1	1704-724	Rear Shock Link	Steel	1 lb
2	1	2704-175	Fox Float 2 Air Shock	Var	3.2 lbs

PROPRIETARY AND CONFIDENTIAL
THE INFORMATION CONTAINED IN THIS DRAWING IS THE SOLE PROPERTY OF THE UNIVERSITY OF MAINE. ANY REPRODUCTION IN PART OR AS A WHOLE WITHOUT THE WRITTEN PERMISSION OF THE UNIVERSITY OF MAINE IS PROHIBITED.

		UNLESS OTHERWISE SPECIFIED:		NAME	DATE
		DIMENSIONS ARE IN INCHES	DRAWN	Keith Jewett	11/13/14
		TOLERANCES:	CHECKED		
		FRACTIONAL ±	ENG APPR.		
		ANGULAR: MACH ± BEND ±	MFG APPR.		
		TWO PLACE DECIMAL ±	Q.A.		
		THREE PLACE DECIMAL ±	COMMENTS:		
		INTERPRET GEOMETRIC TOLERANCING PER:			
		MATERIAL			
		Var			
		FINISH			
		Var			
NEXT ASSY	USED ON				
APPLICATION		DO NOT SCALE DRAWING			

Parts to be Removed

TITLE: **Current Skid Details**

SIZE	DWG. NO.	REV
A	0000-00-01	-
SCALE: Var	WEIGHT: 43 lbs	SHEET 3 OF 3

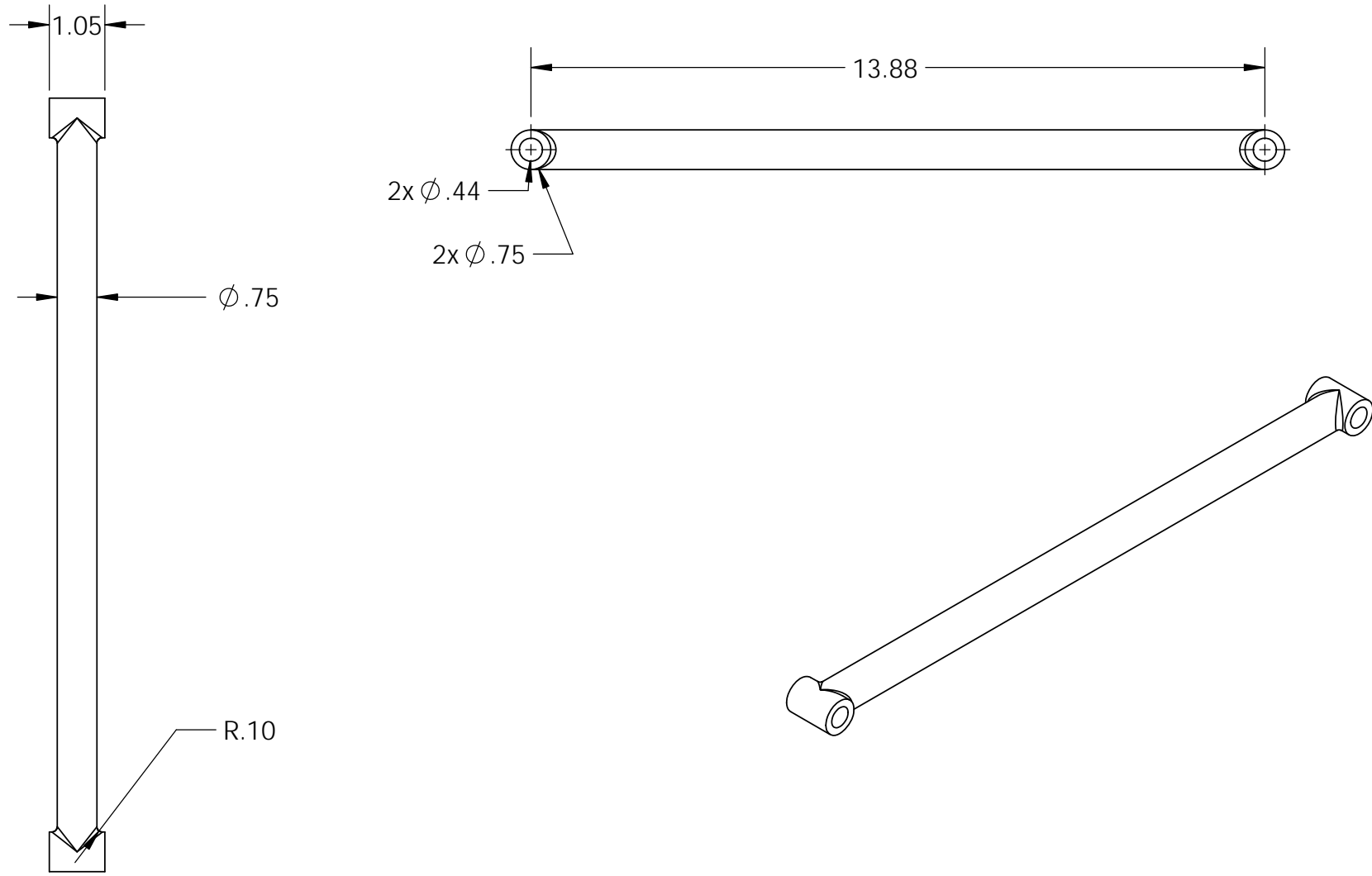

PROPRIETARY AND CONFIDENTIAL
 THE INFORMATION CONTAINED IN THIS DRAWING IS THE SOLE PROPERTY OF THE UNIVERSITY OF MAINE. ANY REPRODUCTION IN PART OR AS A WHOLE WITHOUT THE WRITTEN PERMISSION OF THE UNIVERSITY OF MAINE IS PROHIBITED.

		UNLESS OTHERWISE SPECIFIED:		NAME	DATE
		DIMENSIONS ARE IN INCHES	DRAWN	Izaak Lachapelle	1/4/14
		TOLERANCES:	CHECKED		
		FRACTIONAL ±	ENG APPR.		
		ANGULAR: MACH ± BEND ±	MFG APPR.		
		TWO PLACE DECIMAL ±	Q.A.		
		THREE PLACE DECIMAL ±	COMMENTS:		
		INTERPRET GEOMETRIC TOLERANCING PER:			
		MATERIAL			
		Steel			
		FINISH			
		Black Powdercoat			
NEXT ASSY	USED ON				
APPLICATION		DO NOT SCALE DRAWING			

Part to be Removed		
TITLE: Rear Shock Link		
SIZE A	DWG. NO. 1704-724	REV -
SCALE: 1:3	WEIGHT: 1 lb	SHEET 1 OF 1

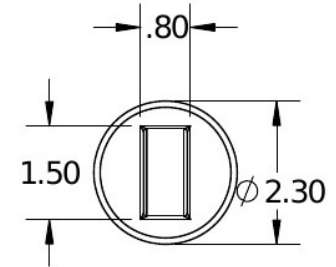
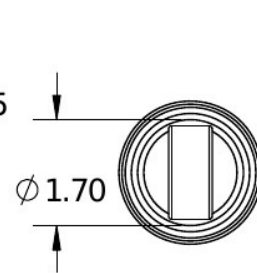
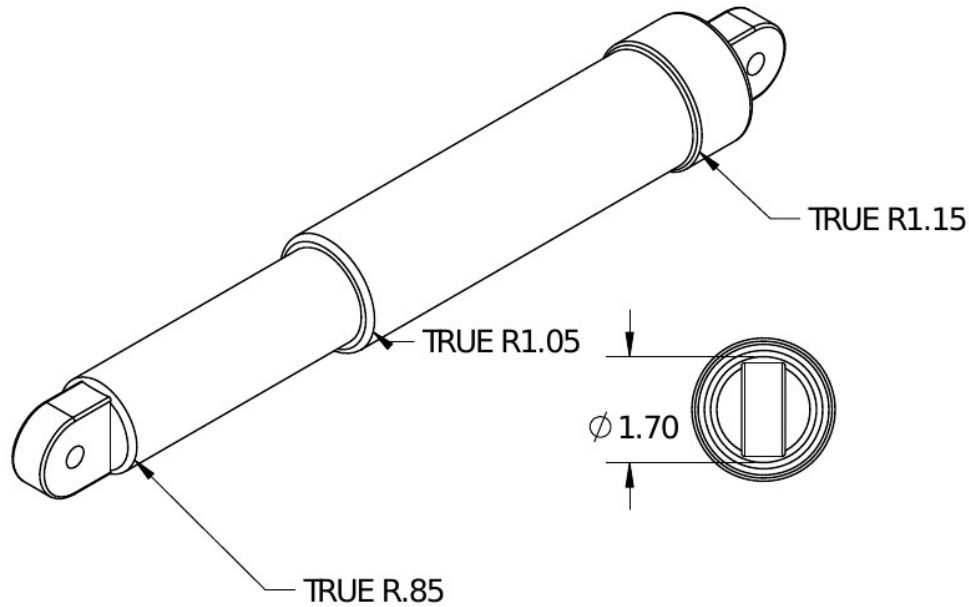
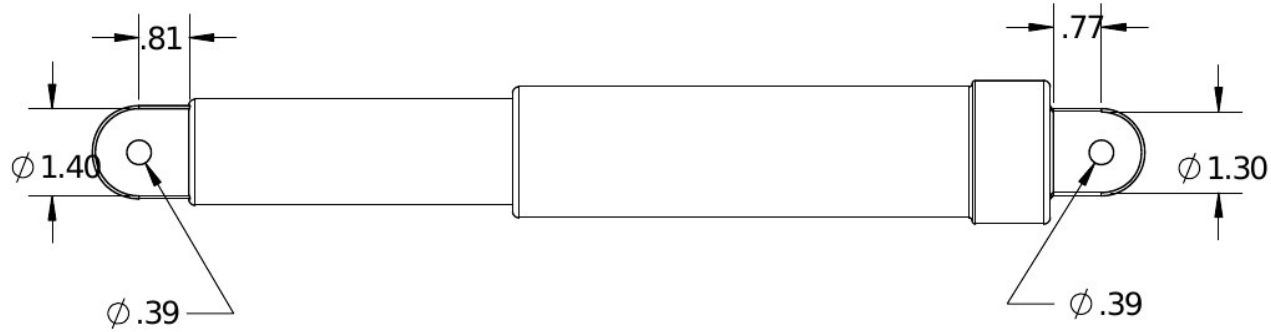
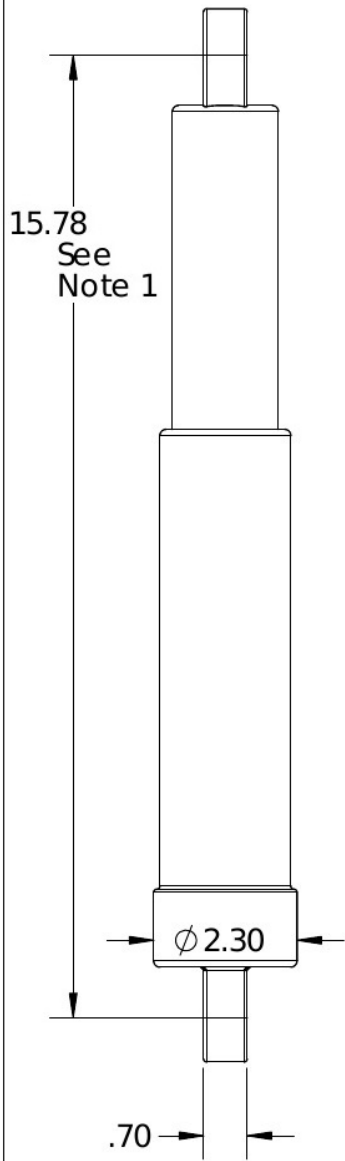

Notes
 1: 15.78 when fully extended
 10.58 when fully retracted

PROPRIETARY AND CONFIDENTIAL
 THE INFORMATION CONTAINED IN THIS DRAWING IS THE SOLE PROPERTY OF THE UNIVERSITY OF MAINE. ANY REPRODUCTION IN PART OR AS A WHOLE WITHOUT THE WRITTEN PERMISSION OF THE UNIVERSITY OF MAINE IS PROHIBITED.

		UNLESS OTHERWISE SPECIFIED:		NAME	DATE
		DIMENSIONS ARE IN INCHES	DRAWN	Gavin Lee	11/4/14
		TOLERANCES:	CHECKED		
		FRACTIONAL ±	ENG APPR.		
		ANGULAR: MACH ± BEND ±	MFG APPR.		
		TWO PLACE DECIMAL ±	Q.A.		
		THREE PLACE DECIMAL ±	COMMENTS:		
		INTERPRET GEOMETRIC TOLERANCING PER:			
		MATERIAL			
		Aluminum			
NEXT ASSY	USED ON	FINISH			
		Black			
APPLICATION		DO NOT SCALE DRAWING			

Part to be Removed

TITLE:
**Fox Float 2
 Air Shock**

SIZE	DWG. NO.	REV
A	2704-175	-
SCALE: 1:3	WEIGHT: 3.2 lbs	SHEET 1 OF 1

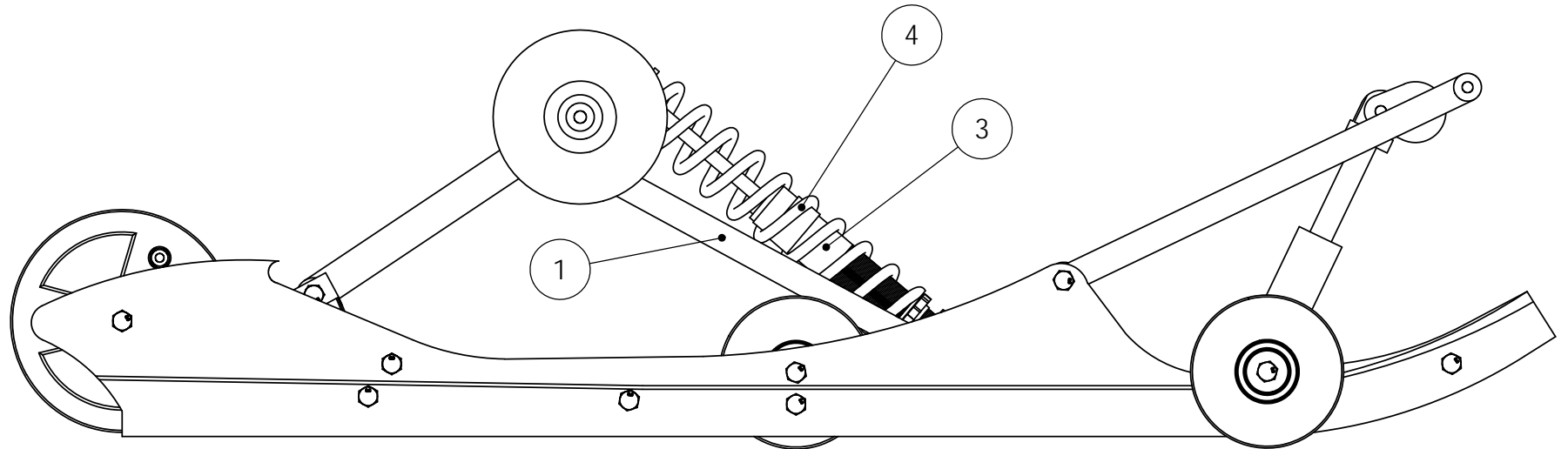
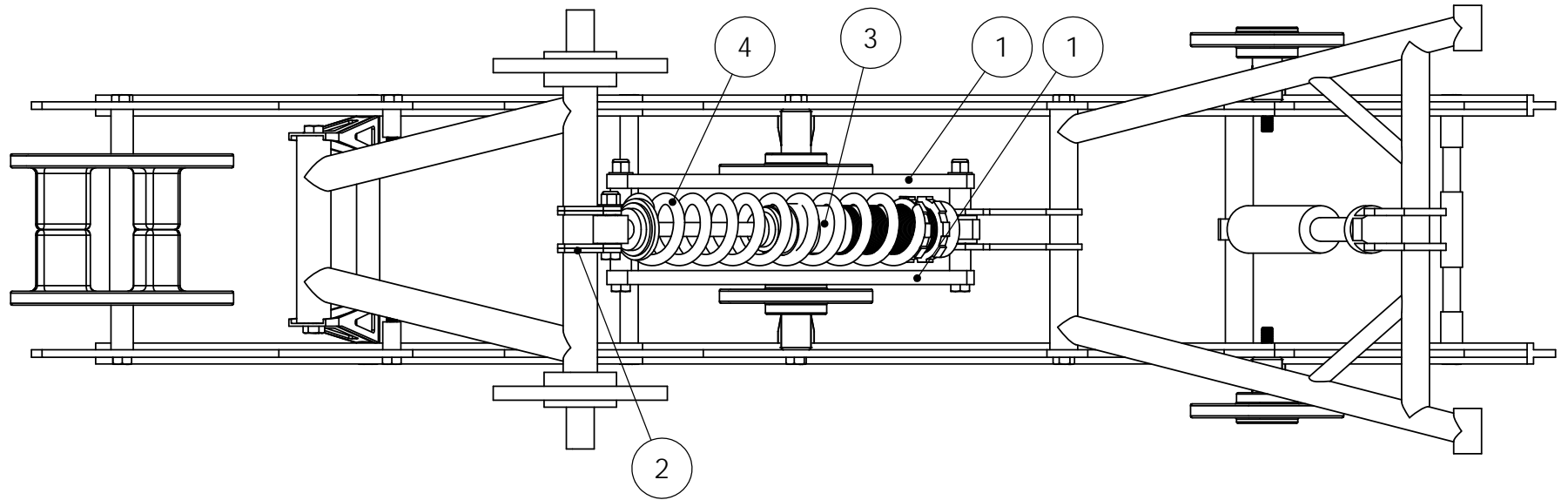

PROPRIETARY AND CONFIDENTIAL
 THE INFORMATION CONTAINED IN THIS DRAWING IS THE SOLE PROPERTY OF THE UNIVERSITY OF MAINE. ANY REPRODUCTION IN PART OR AS A WHOLE WITHOUT THE WRITTEN PERMISSION OF THE UNIVERSITY OF MAINE IS PROHIBITED.

		UNLESS OTHERWISE SPECIFIED:		NAME	DATE
		DIMENSIONS ARE IN INCHES	DRAWN	Blaine H.	11/4/14
		TOLERANCES:	CHECKED		
		FRACTIONAL ±	ENG APPR.		
		ANGULAR: MACH ± BEND ±	MFG APPR.		
		TWO PLACE DECIMAL ±	Q.A.		
		THREE PLACE DECIMAL ±	COMMENTS:		
		INTERPRET GEOMETRIC TOLERANCING PER:			
		MATERIAL			
		Various			
		FINISH			
		Various			
NEXT ASSY	USED ON				
APPLICATION		DO NOT SCALE DRAWING			

Parts to be Installed		
TITLE:		
Shock Installation Assembly		
SIZE	DWG. NO.	REV
A	0000-00-02	-
SCALE: 1:20	WEIGHT: 44 lbs	SHEET 1 OF 3

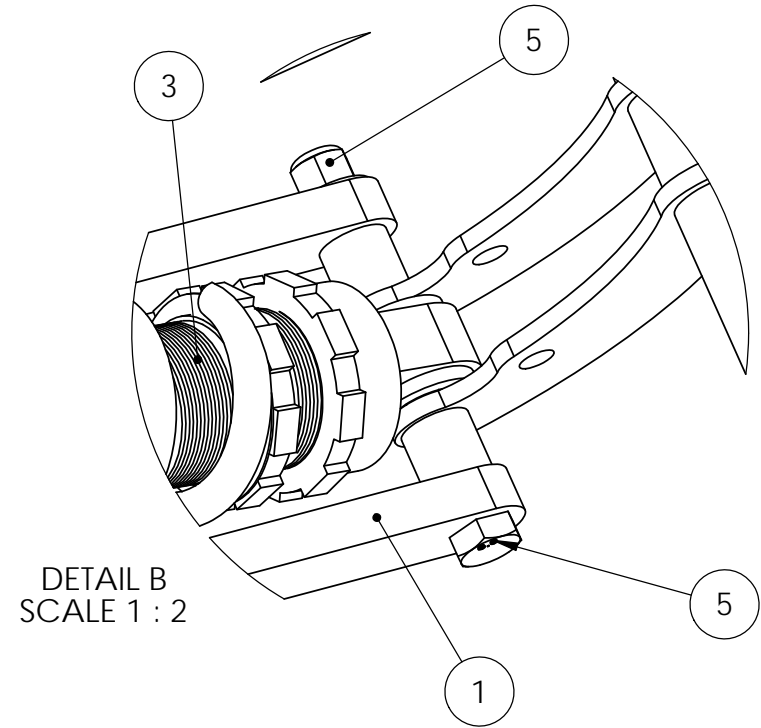
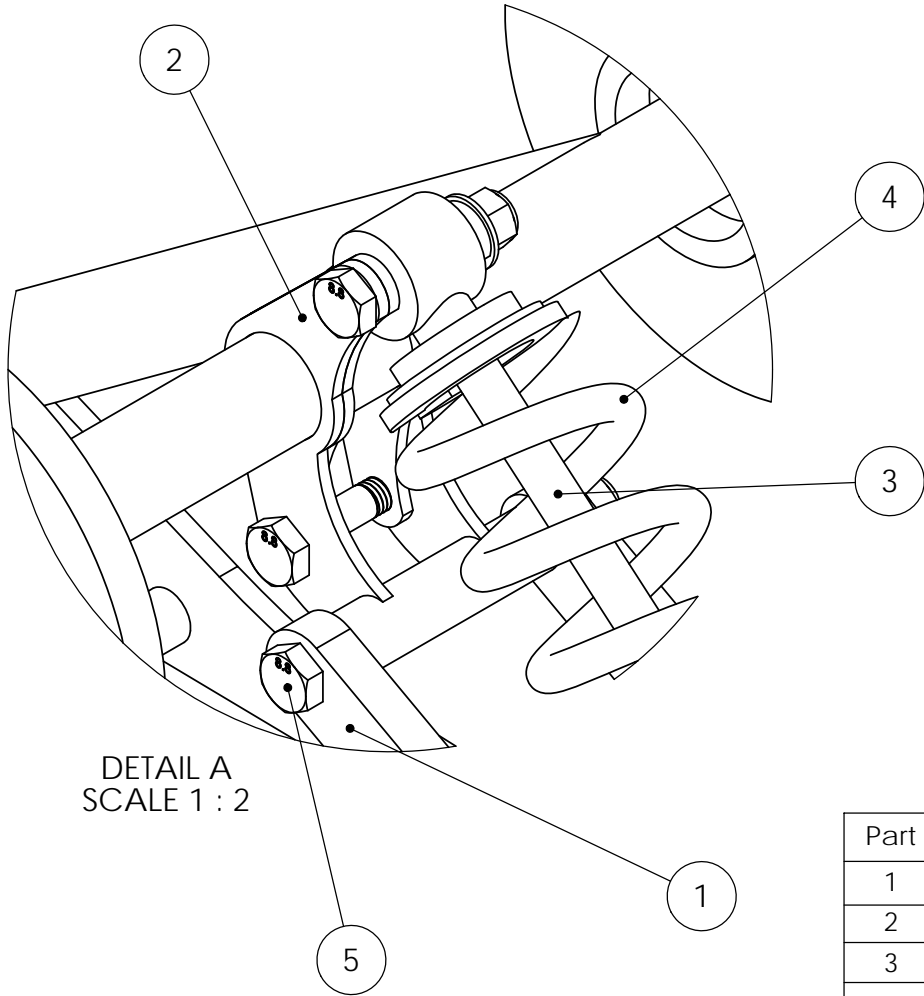

Part	Quantity	Mfr Num	Description	Material	Weight
1	2	73-11-001 (kit)	Hygear Suspension Linkage	Aluminum	.7 lbs
2	1	73-11-001 (kit)	Hygear Linkage Plate	Steel	1 lb
3	1	2704-173	Fox Zero Pro Coil Shock	Various	2.2 lbs
4	1	2703-502	Arctic Cat Stock Rear Arm Spring 175lb	Steel	2.5 lbs
5	2	73-11-001 (kit)	Nut and Bolt	Steel	<.5lbs

PROPRIETARY AND CONFIDENTIAL
 THE INFORMATION CONTAINED IN THIS DRAWING IS THE SOLE PROPERTY OF THE UNIVERSITY OF MAINE. ANY REPRODUCTION IN PART OR AS A WHOLE WITHOUT THE WRITTEN PERMISSION OF THE UNIVERSITY OF MAINE IS PROHIBITED.

		UNLESS OTHERWISE SPECIFIED:		NAME	DATE
		DIMENSIONS ARE IN INCHES	DRAWN	Keith Jewett	11/13/14
		TOLERANCES:	CHECKED		
		FRACTIONAL ±	ENG APPR.		
		ANGULAR: MACH ± BEND ±	MFG APPR.		
		TWO PLACE DECIMAL ±	Q.A.		
		THREE PLACE DECIMAL ±	COMMENTS:		
		INTERPRET GEOMETRIC TOLERANCING PER:			
		MATERIAL			
		Var			
NEXT ASSY	USED ON	FINISH			
		Var			
		APPLICATION			
		DO NOT SCALE DRAWING			

Parts to be Installed		
TITLE: Stock Installation Details		
SIZE A	DWG. NO. 0000-00-02	REV -
SCALE: Var	WEIGHT: 44 lbs	SHEET 3 OF 3

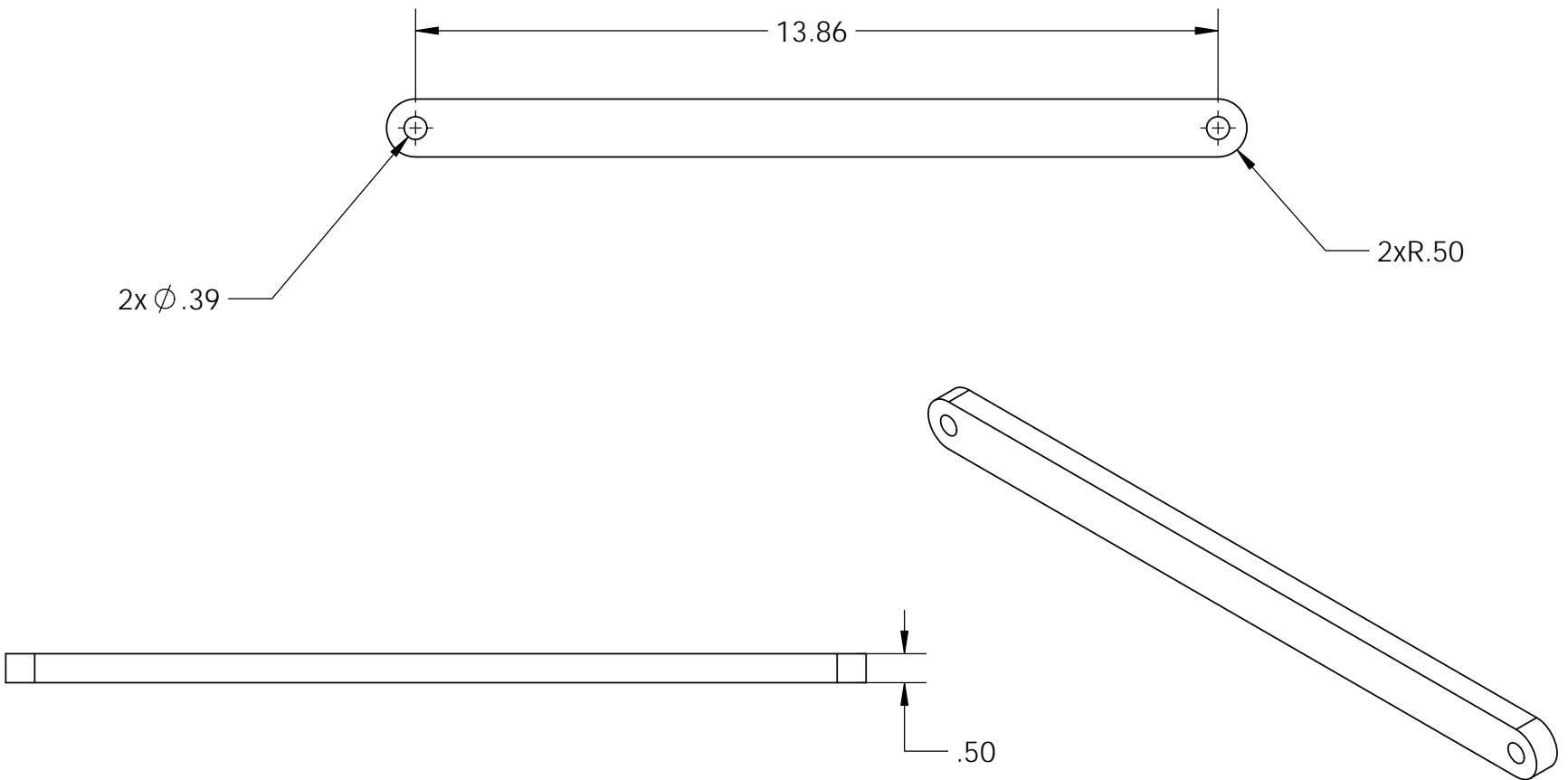

PROPRIETARY AND CONFIDENTIAL
 Several dimensions used by permission of HyGear Suspension.

		UNLESS OTHERWISE SPECIFIED:		NAME	DATE	Part to be Installed			
		DIMENSIONS ARE IN INCHES	DRAWN	Izaak Lachapelle	10/30/14			TITLE: Hygear Susp. Linkage	
		TOLERANCES: FRACTIONAL ± ANGULAR: MACH ± BEND ± TWO PLACE DECIMAL ± THREE PLACE DECIMAL ±	CHECKED						
		INTERPRET GEOMETRIC TOLERANCING PER:	ENG APPR.			SIZE	DWG. NO.	REV	
		MATERIAL Aluminum	MFG APPR.			A	73-11-001	-	
NEXT ASSY	USED ON	FINISH Uncoated	Q.A.			SCALE: 1:3 WEIGHT: .7 lbs SHEET 1 OF 2			
APPLICATION		DO NOT SCALE DRAWING	COMMENTS:						

5

↑

4

↑

3

↑

2

↑

1

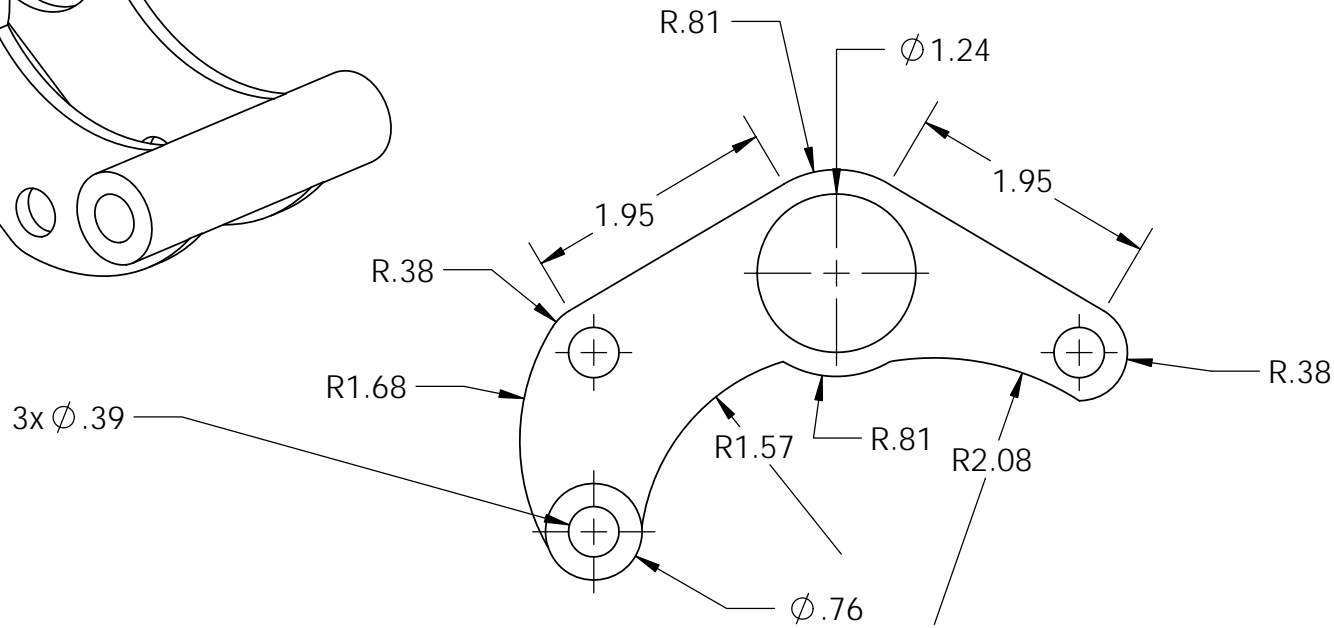
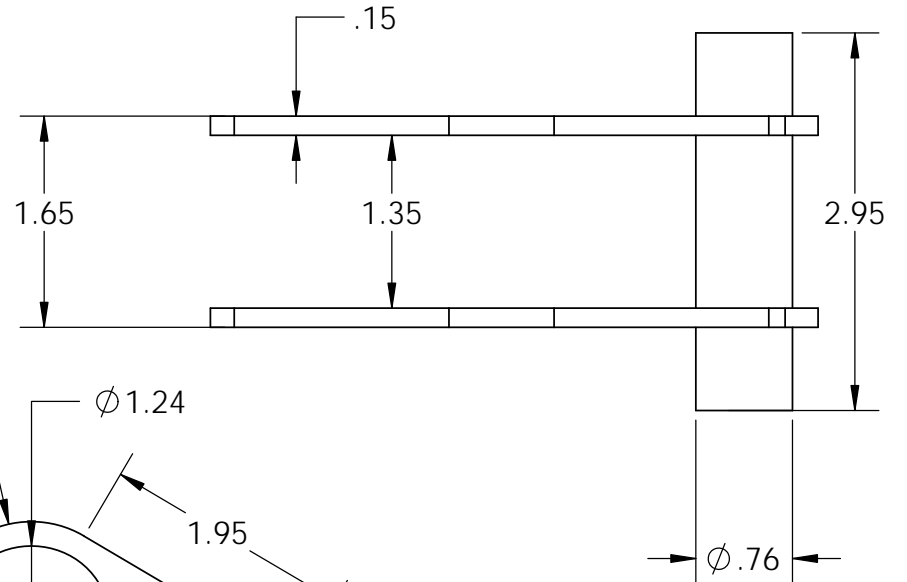
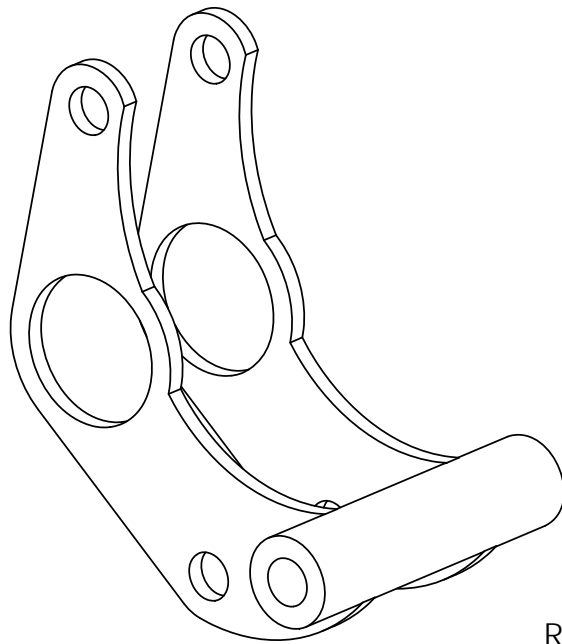

PROPRIETARY AND CONFIDENTIAL
 THE INFORMATION CONTAINED IN THIS DRAWING IS THE SOLE PROPERTY OF THE UNIVERSITY OF MAINE. ANY REPRODUCTION IN PART OR AS A WHOLE WITHOUT THE WRITTEN PERMISSION OF THE UNIVERSITY OF MAINE IS PROHIBITED.

		UNLESS OTHERWISE SPECIFIED:		NAME	DATE
		DIMENSIONS ARE IN INCHES	DRAWN	Izaak L.	11/4/14
		TOLERANCES:	CHECKED		
		FRACTIONAL ±	ENG APPR.		
		ANGULAR: MACH ± BEND ±	MFG APPR.		
		TWO PLACE DECIMAL ±	Q.A.		
		THREE PLACE DECIMAL ±	COMMENTS:		
		INTERPRET GEOMETRIC TOLERANCING PER:			
		MATERIAL			
		Steel			
		FINISH			
		Black			
NEXT ASSY	USED ON				
APPLICATION		DO NOT SCALE DRAWING			

Part to be Installed		
TITLE: Hygear Linkage Plate		
SIZE A	DWG. NO. 73-11-001	REV -
SCALE: 1:2	WEIGHT: 1 lb	SHEET 2 OF 2

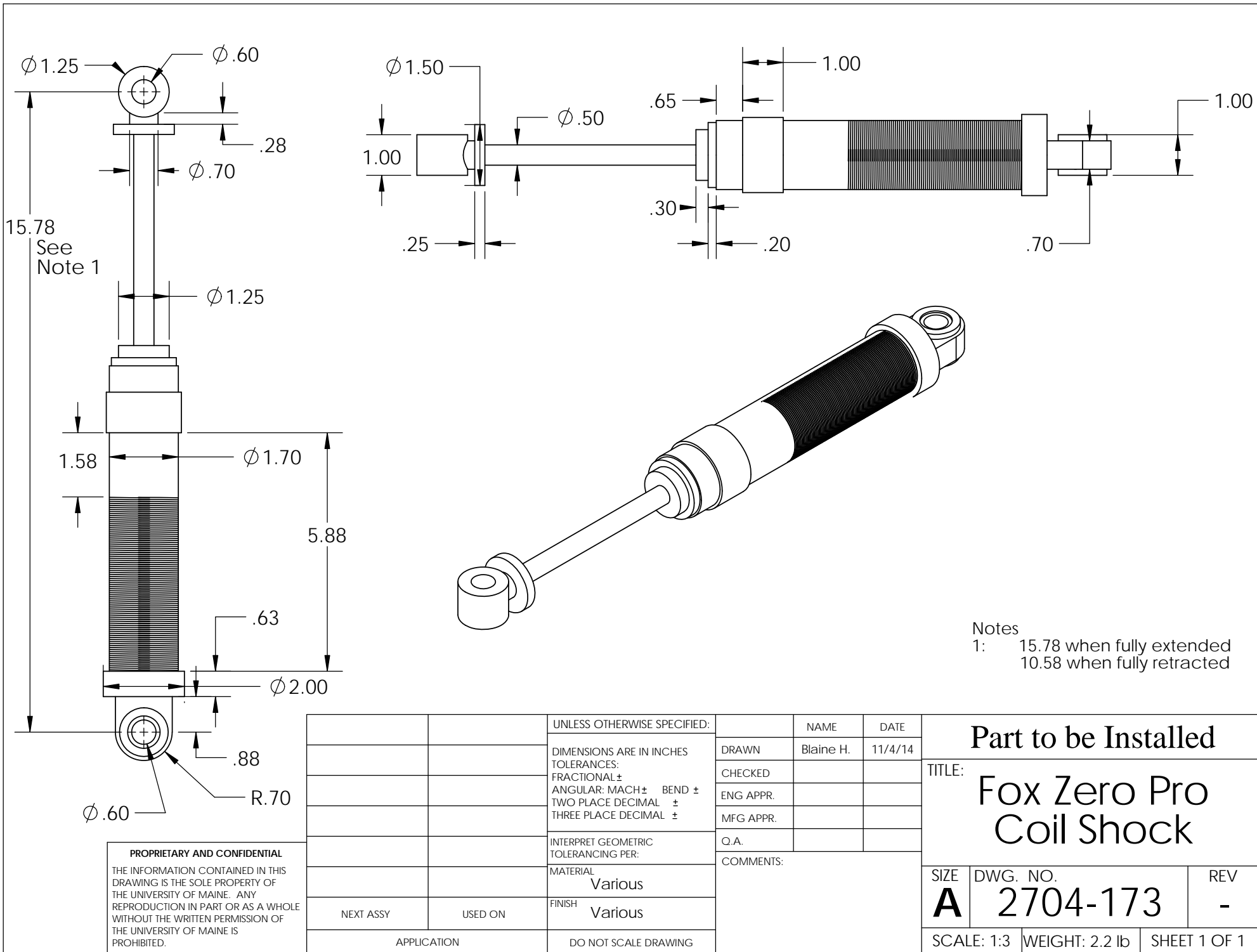

Notes
 1: 15.78 when fully extended
 10.58 when fully retracted

PROPRIETARY AND CONFIDENTIAL
 THE INFORMATION CONTAINED IN THIS DRAWING IS THE SOLE PROPERTY OF THE UNIVERSITY OF MAINE. ANY REPRODUCTION IN PART OR AS A WHOLE WITHOUT THE WRITTEN PERMISSION OF THE UNIVERSITY OF MAINE IS PROHIBITED.

		UNLESS OTHERWISE SPECIFIED:		NAME	DATE
		DIMENSIONS ARE IN INCHES	DRAWN	Blaine H.	11/4/14
		TOLERANCES:	CHECKED		
		FRACTIONAL ±	ENG APPR.		
		ANGULAR: MACH ± BEND ±	MFG APPR.		
		TWO PLACE DECIMAL ±	Q.A.		
		THREE PLACE DECIMAL ±	COMMENTS:		
		INTERPRET GEOMETRIC TOLERANCING PER:			
		MATERIAL			
		Various			
		FINISH			
		Various			
NEXT ASSY	USED ON				
APPLICATION		DO NOT SCALE DRAWING			

Part to be Installed		
TITLE: Fox Zero Pro Coil Shock		
SIZE	DWG. NO.	REV
A	2704-173	-
SCALE: 1:3	WEIGHT: 2.2 lb	SHEET 1 OF 1

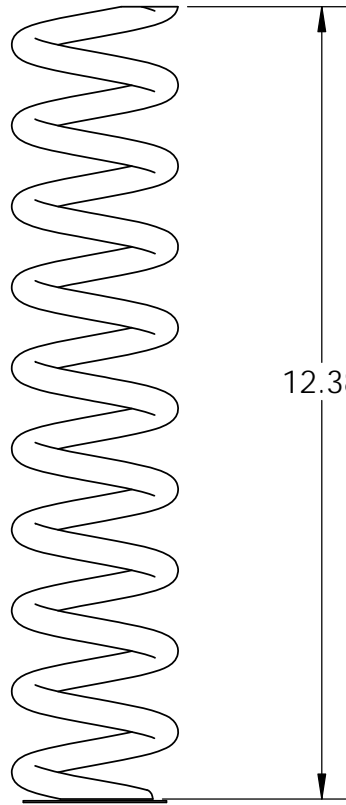

12.38

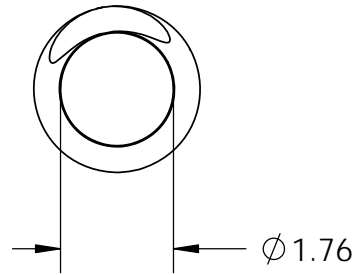

Ø1.76

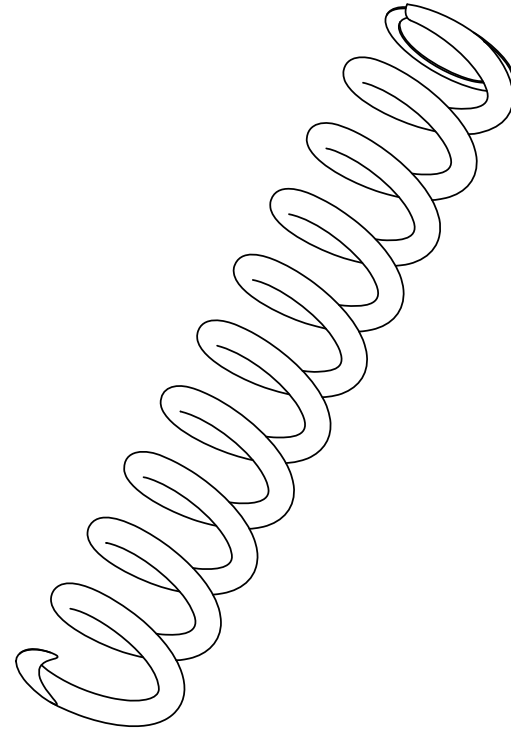

PROPRIETARY AND CONFIDENTIAL
 THE INFORMATION CONTAINED IN THIS DRAWING IS THE SOLE PROPERTY OF THE UNIVERSITY OF MAINE. ANY REPRODUCTION IN PART OR AS A WHOLE WITHOUT THE WRITTEN PERMISSION OF THE UNIVERSITY OF MAINE IS PROHIBITED.

		UNLESS OTHERWISE SPECIFIED:		NAME	DATE	Part to be Installed		
		DIMENSIONS ARE IN INCHES	DRAWN	Gavin Lee	11/6/14	TITLE:		
		TOLERANCES:	CHECKED			Arctic Cat Stock		
		FRACTIONAL ±	ENG APPR.			Rear Arm Spring		
		ANGULAR: MACH ± BEND ±	MFG APPR.			SIZE	DWG. NO.	REV
		TWO PLACE DECIMAL ±	Q.A.			A	2703-502	-
		THREE PLACE DECIMAL ±	COMMENTS:			SCALE: 1:3	WEIGHT: 2.5 lbs	SHEET 1 OF 1
		INTERPRET GEOMETRIC TOLERANCING PER:						
		MATERIAL						
		Steel						
		FINISH						
		Black Powdercoat						
	NEXT ASSY	USED ON						
	APPLICATION							
			DO NOT SCALE DRAWING					

5

4

3

2

1